

NOTE:
 Spacers or standoffs must be used to keep bottom of board from touching the mounting surface, minimum of 3/8" for proper clearance

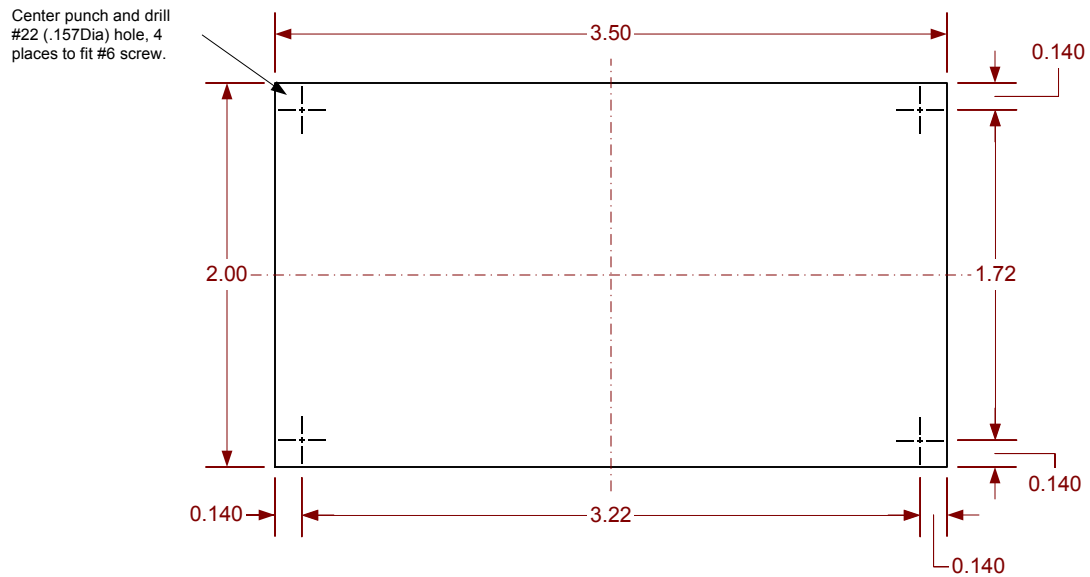

Instructions:
 Print this document at a scale of 1:1
 Cut out the outline of the box above.
 Tape this on your mounting surface in the location required
 Center punch the four location for the screws.
 Drill #22 (.157Dia) hole to fit a #6 screw

Pluggable I/O Board Drill Template

2/5/2016	AEJ	16022702	REV: A
----------	-----	----------	--------

Scale: 1:1

Dimension are in inches.
 +/- .015 Tolerance



Pencom Design, Inc.
 PO Box 645
 Trumbauersville, PA 18970
 Copyright (C) 2016