



**Pencom Design, Inc.**  
**PO Box 870**  
**Trumbauersville, PA 18970-0870**

[Http://www.pencomdesign.com](http://www.pencomdesign.com)

[Sales@pencomdesign.com](mailto:Sales@pencomdesign.com)

## INSTRUCTION MANUAL

# Programmable Event Control Timer

### Single Channel Versions

**Model: S1RLY-EXT (Shown)**

**Model: S1RLY-INT**

### Dual Channel Versions

**Model: S1RLY-EXT**

**Model: S1RLY-INT**

### Introduction

Thank you for buying our Programmable Event Control Timer (PECT).

The goal of Pencom Design is to provide top quality equipment at low cost. All of our products are designed and tested in-house to meet our high quality standards.

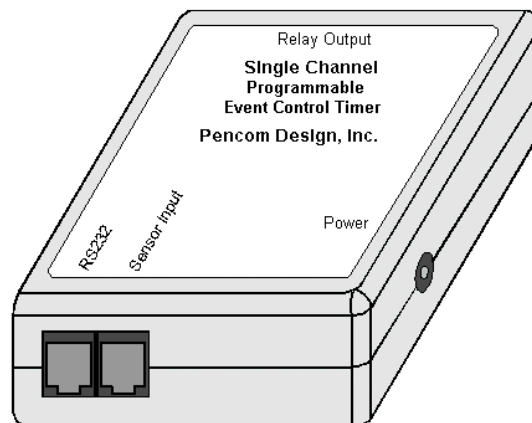

### Features

Single or dual Channel Programmable Event Control Timer with three events (delay event, event duration, and recycle delay) with up to 240 seconds (four minutes) per individual event.

- Delay event -will delay the start of a cycle after triggered by the sensor.
- Event Duration – the time the device or event will be active (ON).
- Recycle Delay – the delay after the event is completed before the timer will respond to another trigger from the sensor.

Software programmable using our ECP Software (Event Control Programmer) a windows based software designed specifically to program our family of event controllers. See our website to download the software.

Stand alone operation – once the PECT is programmed by the software the unit is fully self-contained. Applying power to the device after programming will immediately start its event cycle when it receives a signal from the sensor. The PECT may also be operated from the PC to test its timing cycle.

Easy hook up using modular telephone cable. Designed to work with our miniature PIR Sensors, but can be easily interfaced to a switch or other 5 VDC input device.

Single or dual channel 10 Amp @ 250VAC SPDT Relay outputs.

Two Board designs available in both 1 & 2 channel versions.

- Circuit board mounted in an enclosure with external wall transformer
- Bare circuit board with internal on-board mounted transformer – for resale enclosed in an animated prop or other device, or for mounting in a customers enclosure.

## Applications

- Animation
  1. Haunted house props or special effects
  2. Animated Christmas decorations
  3. Museum exhibit activation
- Surveillance, camera/VCR activation or intruder alarms
- Automatic door bell
- Lighting applications
- Large scale model railroading, crossing signal application, train location, etc.
- Courtesy lights
- Automated product demonstration
- Voice recorder applications

## Specifications

### Dimensions:

3.25" Wide X 4.38" High X 1.52" Deep, light gray case color

### Connections:

1 or 2	6 Pin RJ-12 Modular Phone Jack(s) for sensor inputs (depends on version)
1	4 pin RJ-11 Modular connector for RS232 (serial communication to PC)
1 or 2	3 contact Terminal block(s) (output)
1	Power Jack for AC wall transformer (depends on version see power requirements)
1	120VAC Terminal Block (depends on version see power requirements)

Uses either 4 pin RJ-11 or 6 pin RJ-12 modular cable for connection to the sensors. The 6-pin cable extends the distance from the sensor to the connected device (Programmable Event Control Timer).

If your connecting with our sensors make sure you use the normal telephone cable wiring only (Reverse/cross wired configuration), see instructions figures 3 & 4 below. If incorrect wires are used the sensors or PECT will be damaged.

Modular cables not included, but may be purchased through us for proper configuration.

### Power Requirements:

9 Volts DC @ 300ma wall transformer (Models S1RLY-EXT & S1RLY-EXT)  
120 VAC 50/60 HZ internal transformer (Models S1RLY-INT & S1RLY-INT)

### PECT to Sensor Distance:

Typically 200' from sensor to PECT, varies with surrounding noise and cable type

### Operating Temperature & Humidity:

0° to 70° Centigrade, 90% Relative humidity (this device is not waterproof and must be installed in a suitable enclosure if used outdoors)

## Parts Listing

### All Models include:

- 1 - RS232 Modular cable
- 1 - 9 pin Dsub to Modular connector

### Models: S1RLY-EXT (single channel) & S2RLY-EXT (dual channel)

- 1 - With enclosure
- 1 - AC to 9VDC Wall Transformer adapter

### Models: S1RLY-INT (single channel) & S2RLY-INT (dual channel)

- 1 - No enclosure
- 1 - With internal power transformer 120VAC 50/60 Hz with terminal block connection



## Setup Instructions

Connect the sensors, computer, and wall transformer as shown in figure 1 to the PECT.

**Important** make sure you use the proper modular cables when connecting up the PIR sensors to the device, these cables are not supplied with the unit due to variety of length required by the customer. Purchase the cables with your unit to assure correct configuration.

Download and install the ECP (Event Control Programmer) on your IBM compatible personal computer with an available RS232 serial port. Some newer computers may be eliminating the serial ports on these designs, a USB to serial adapter is needed in this situation. If your using line voltage (120VAC) make sure you connect the ground wire from the plug to the device for safety. If this device is used outdoors it must be plugged into a GFI (Ground Fault Interruption) outlet for safety. If your not familiar with high voltage circuits seek the help of a qualified electrician.

Models: S1RLY-INT (single channel) & S2RLY-INT (dual channel), without enclosure have an on-board power transformer that is connected directly to 120VAC with a 2-contact terminal block located next to relay #1 on figure 2, it is not shown on this drawing.

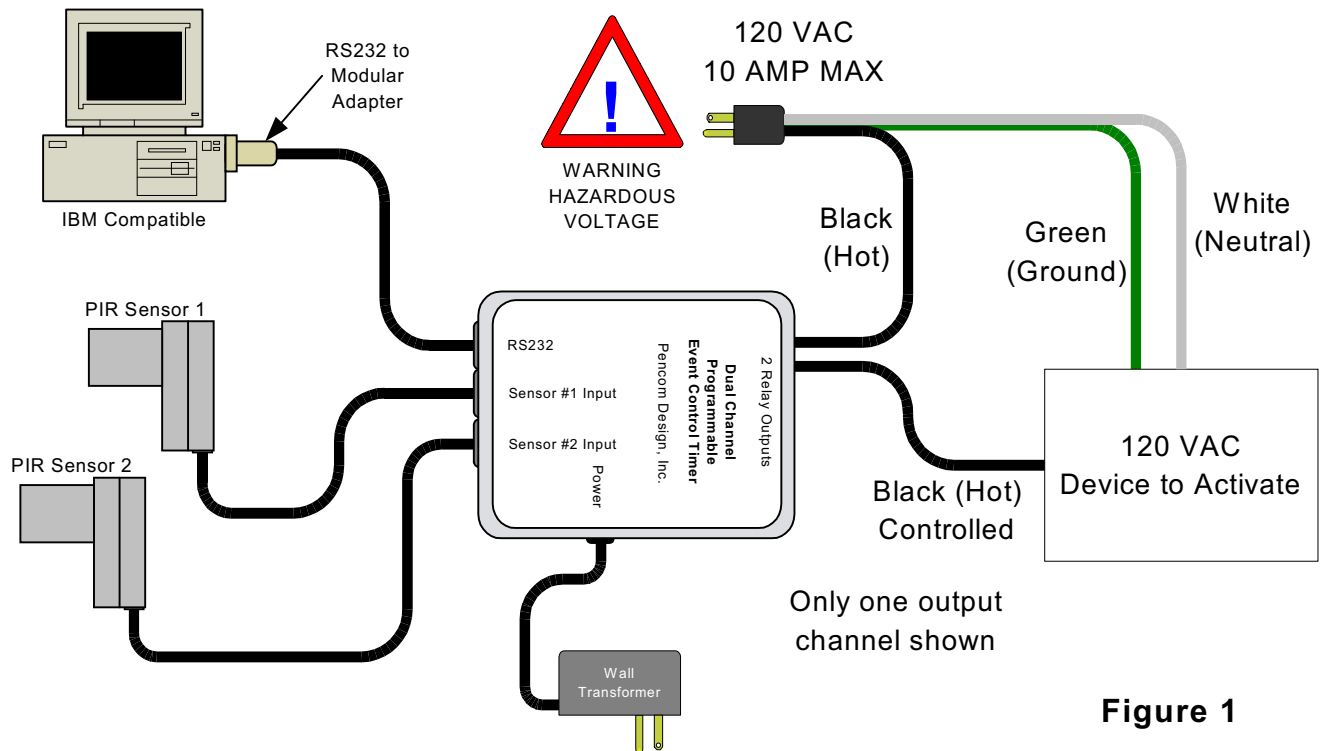

Figure 1

## Connecting Relay Outputs

Remove the four case screws from the back of the PECT. Lift off the top cover and the inside will resemble Figure 2. Depending on what model you have there will be one or two 3-contact terminal blocks marked with NC, COM, NO these are the relay outputs. Warning do not touch any other components on the board since static electricity from your fingers may damage these devices.

Strip the insulation back on your wire approx. ¼ inch. Wire the hot (or positive if DC) side of the power to the COM pin, and the output to the device under control using the NO (normally open) or NC (normally closed) pins depending on your application. Insert the stripped wire into the side of the terminal block and tighten the screw to clamp the wire in place. The terminal blocks are designed for 14-22 AWG wire size. Do not exceed the 10 amp current rating of the relays. Most applications will use the normally open contacts.

Align the wires with the slot in the case making sure the wires are not crimped by the case. Make sure there is no bare wire extending from the case. Re-assemble with the four screws removed earlier.

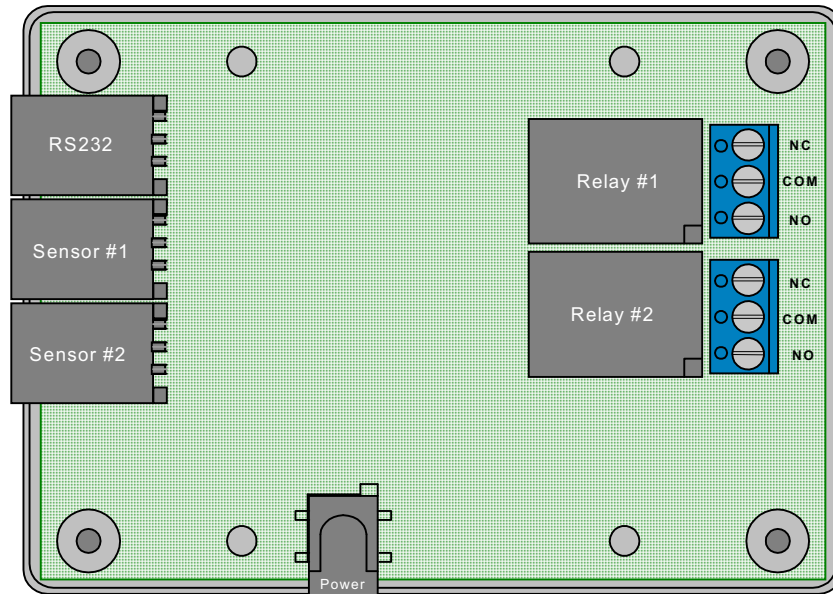

Internal drawing of a 2 Channel PECT, **Figure 2**

### Modular Cable Wiring

Our Programmable Event Control Timers are designed to be used with our Miniature PIR sensors, but they may be used in other applications. **Warning** if you use our PECT with another input source, make sure you apply only 5 VDC to the correct inputs pins, there is no protection circuitry built into the inputs, you may damage the device if the connections or voltage is incorrect.

If this Sensor is used with either of these units, the standard telephone modular cable must be used to connect any of these devices together. **Note: if the wrong cable is used, the PIR and timers will be damaged.** To prevent this damage it's best to purchase the cables from us since we only sell the standard telephone cables which are reverse wired as shown in figure 3 below.

You may use either 4 (RJ-11) or 6 (RJ-12) conductor cables both are 6 position, but the RJ-11 only uses 4 conductors. By using the 6 conductor cable it extends the distance the PIR will operate since you doubling the current capability and reducing the voltage drop.

To assure proper configuration purchase the modular cables with your sensors and PECT, we only sell the 6 conductor wire for maximum sensor to PECT distance.

When routing modular sensor cables, do not place them next to power cables, this will induce noise on the lines and prevent proper operation.

**See figures 3 & 4 below to view diagrams of wiring differences:**

When verifying the proper cable wiring type, hold both ends of the connectors so that the contacts are facing towards you—the colors will be reversed left to right as shown in figure 3 below.

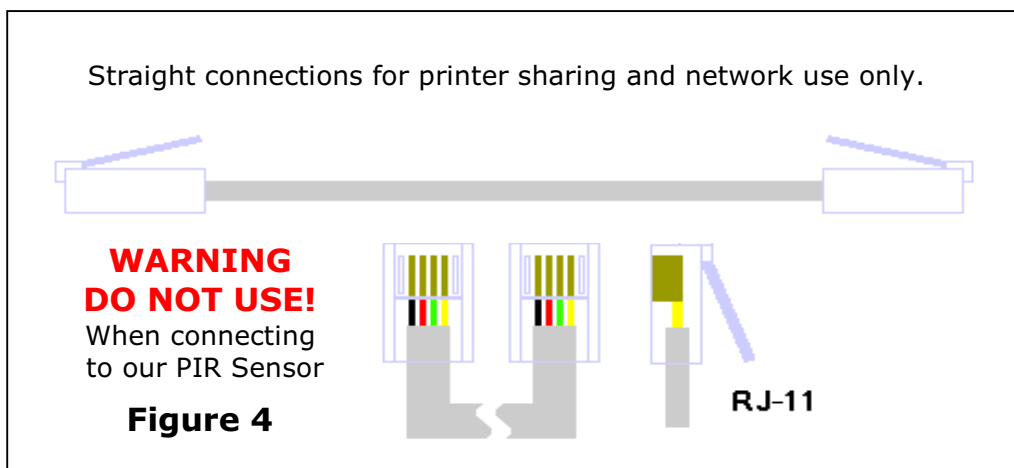
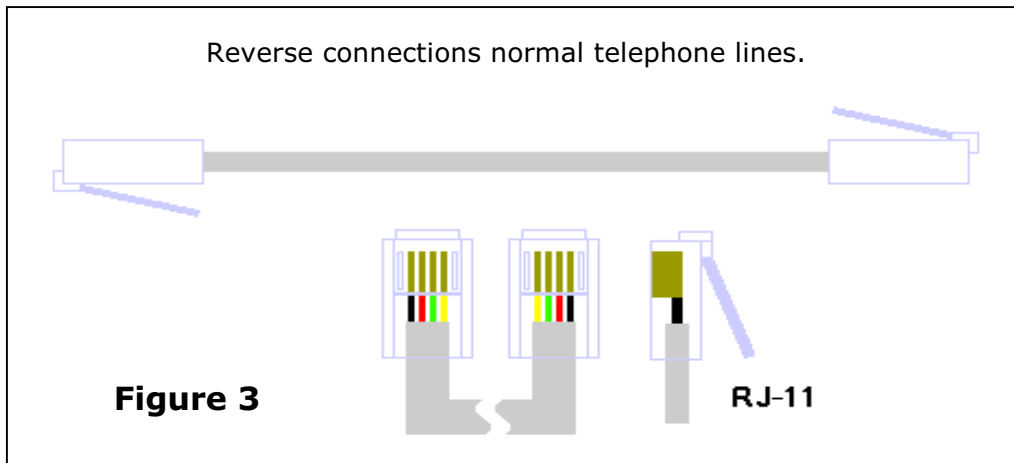

Wiring Diagram for use with a customer supplied sensor (mat, photocell, etc.).

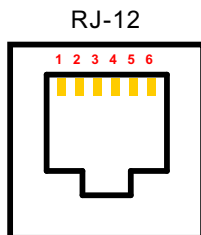

**PECT Modular Jack**  
Wiring Schematic  
 Pins 1&2 – 5-10VDC  
 Pins 3&4 – Pulse Output  
 Pins 5&6 – Ground